



FLOORING AND INTERIOR COVERINGS WITH ENGINEERED STONE.

Instructions for installation

The following instructions should be considered guidelines for ordinary indoor use and are not by any means a substitute for the installer's responsibilities.

If applied in conditions that differ from normal civil construction, such as for example heavy loads, particular thermohygrometric conditions, strong exposure to sun, or large sizes, we recommend contacting specialized technicians for an assessment.

The rules for the proper laying of materials are not substantially different from those of ceramic materials and apply to all Marble-based, Quartz-based and Evo materials.

- The tiles must be stored in a dry, covered area at a temperature of no less than +5°C.
- In normal conditions we recommend quick setting cement-based adhesives with low water content (for example Granirapid by Mapei), the same that are used for ceramics and natural stone. In the case of X-Large tiles, supports or particular stress, two-component polyurethane adhesives should be used. Rosso Levanto and Verde Tirreno contain natural materials that are particularly sensitive to humidity and that is why the use of waterless adhesives is sometimes required.

- Make sure the adhesive sticks to the entire surface of the back of the tiles.

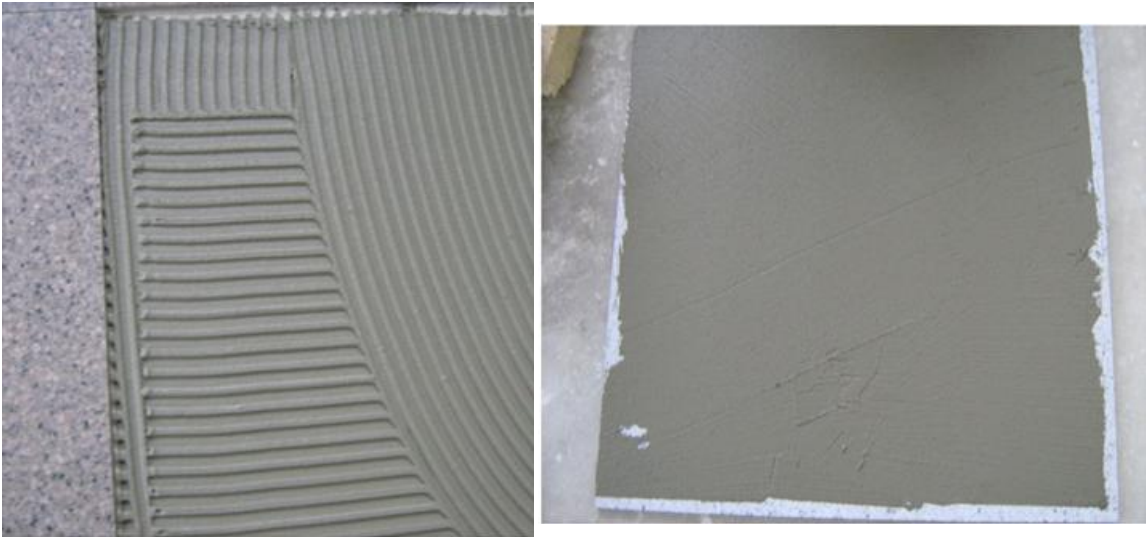

- The substrate must be clean, compact and dry (relative humidity less than 2%) and have a tensile strength of no less than 1 N/m²
- We recommend fixing the tiles with 2-3 mm joints, which can be sealed with standard grout products used for ceramics.
- Expansion joints should be elastic (by using a deformable appropriate jointing system such as silicone or PVC) and must be positioned along the walls. The surface extensions should be about 4-5 mts x 4-5 mts.

Mechanical Joints:

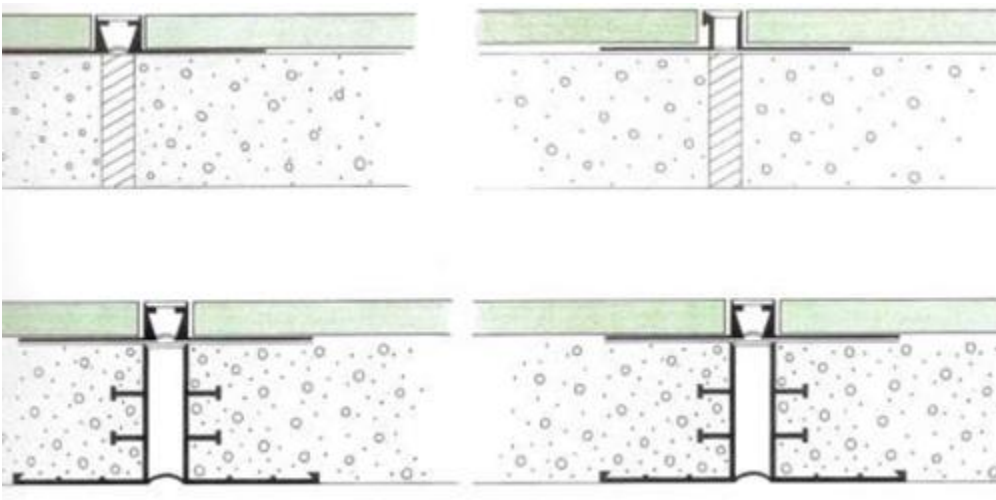

Non-Mechanical Joints:

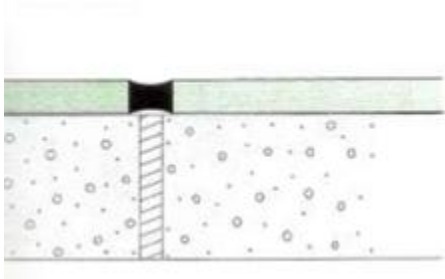

- Engineered Stone can be used for heated floors. In this case the substrate must be absolutely dry and the expansion joints must be positioned very carefully.
- The tiles can easily be cut and adapted to size on site.
- All products, especially marble-based ones, must be protected after the tiles have been installed, so as to avoid damage and scratches during construction work.
- Adhesive or sealant stains must be removed as quickly as possible. The construction site must be cleaned with neutral detergents. The use of acidic detergents must be totally avoided on marble-based materials.
- Cut to size pieces, steps and windowsills should all be installed in the same way as natural stone.

External Cladding

- the installation of external cladding must be carried out by a firm that specializes in this work, and which has the necessary equipment and experience. The project for a façade must be prepared by a technical professional who will take into consideration, among many other factors, the following: location, type of cladding, type of principle structure building height, wind speed, maximum and minimum temperature, maximum daily temperature variation, etc. The following drawings show some examples of “traditional” and “Technologically” advanced systems.

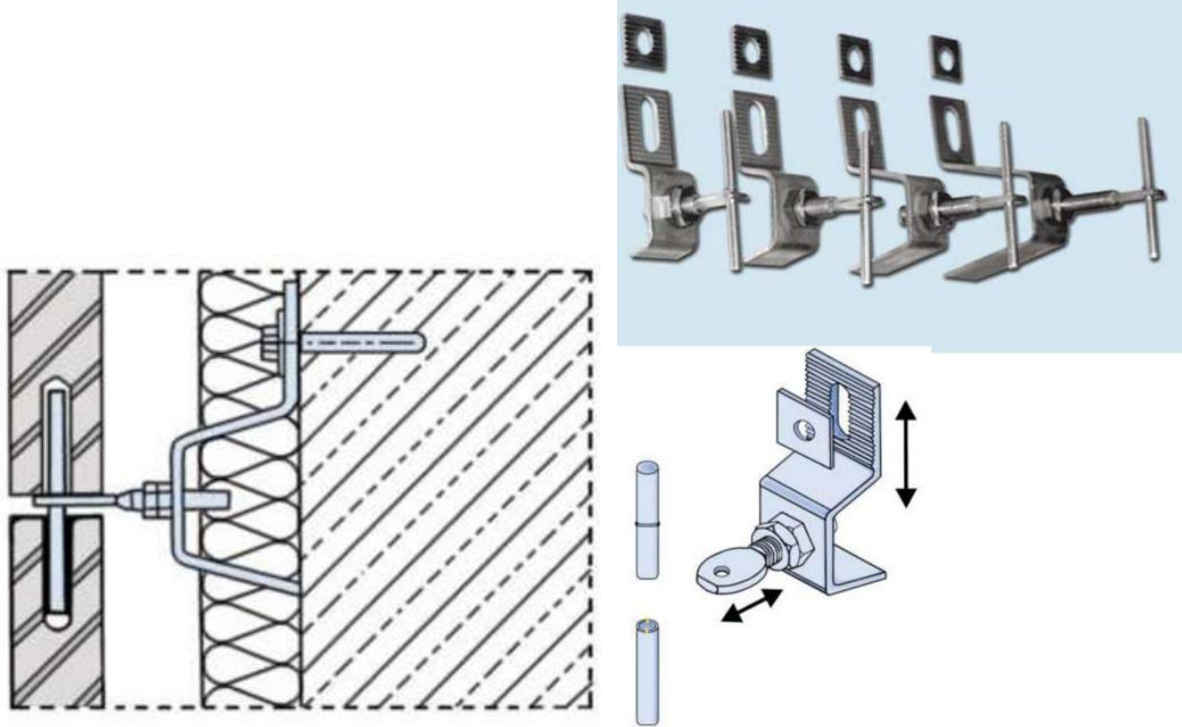

The cutting of the slabs into tiles or cut-to-size pieces.

- The slabs produced are especially suitable for kitchen worktops, bathroom furniture tops, windowsills, steps, flooring or fireplace surrounds.

The following sizes are available:

- Marble/resin: 3050x1230 mm; thickness 12 , 20, 30 mm or thicker if requested

- Evo: 3050x1230 mm; thickness 12, 20, 30 mm

- Quartz/resin: 1230x3050 mm or 1410x3050 mm; thickness 12, 20, 30 mm.

The surface of natural stone can be polished, honed, brushed or finished in different ways on request (sandblasted, bush-hammered or anticato).

- Tiles are produced by cutting slabs on the fully automated industrial line, with certified procedure that guarantee the highest quality standards
 - Standard size tiles are:
 - 30*30, 30*60, 30*75, 30*100
 - 40*40, 40*60, 40*75, 40*100
 - 60*60, 60*75, 60*100, 60*120
 - 80*40, 80*60, 80*75, 80*80, 80*100, 80*150
 - 90*45, 90*60, 90*75, 90*90, 90*100, 90*150
 - 120*60, 120*75, 120*100, 120*150

Or according to the cutting list. Upon request done with maximum optimization to reduce waste.



LONG/SHORT EDGES

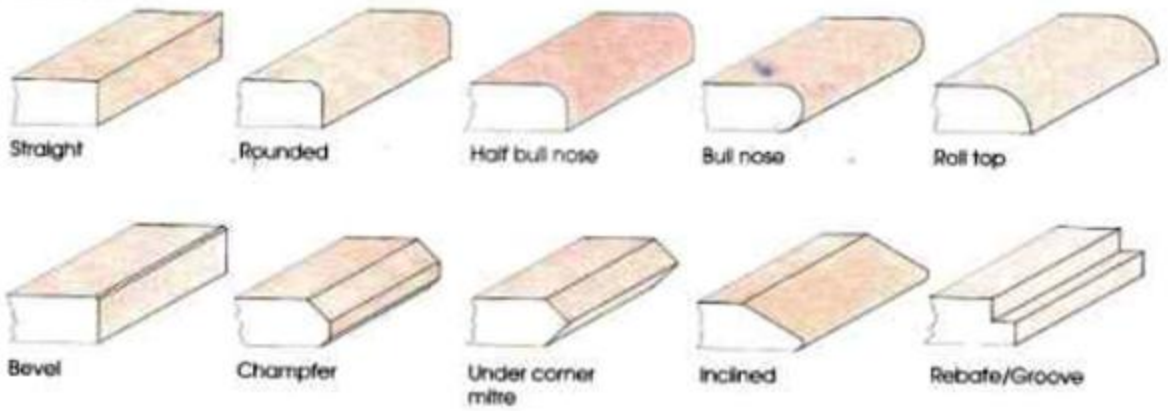

CUTS



EXTERNAL ANGLE DETAILS

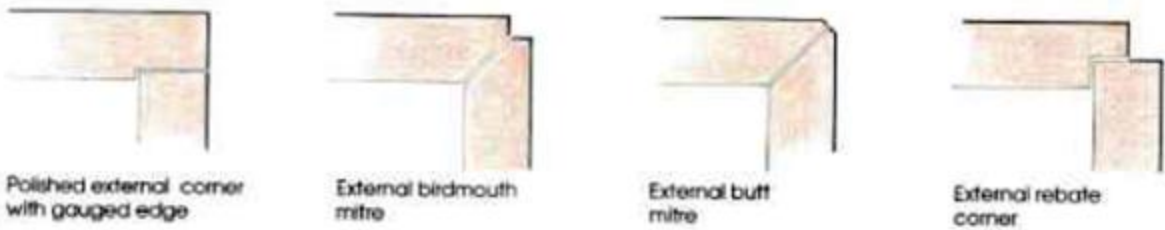

STAIR SKIRTING

